



### Acceptance of the control command

For presses with automatic upward movement, it must be ensured that access in the danger zone is protected either by an additional protective device (e.g. ESPE) or inherently

For presses with automatic upward movement, safe Inherently safe design is achieved by avoiding hazards or reducing risks through an appropriate choice of design features of the machinery itself and/or interaction between the exposed persons and the machinery.

### Selection of two-hand circuits

No faulty/automatic start due to insertion/removal of two-hand controls.

No faulty/self start due to preselection of two-hand controls.

The press may only be started if the two-hand controls preselected by the selector switch are connected.

### Note

Product-specific press standards may have additional requirements for two-hand controls.

**ISSA-Section Machine and System Safety**  
**Project Group "Control Devices"**  
 Dynamostrasse 7-11  
 D – 68165 Mannheim  
[info@ivss.org](mailto:info@ivss.org)  
[www.safe-machines-at-work.org](http://www.safe-machines-at-work.org)



©: Thomas Schulz BGHM

## Two-hand control on presses

Two-hand controls are devices which force the operator to keep his hands outside the danger zones during the dangerous closing movement in order to avoid hand injuries.

Two-hand controls used on power-driven metalworking presses to protect against injuries to the hand during hazardous closing movements or other auxiliary movements (e.g. transfer) must comply with DIN EN ISO 13851 "Safety of machinery - Two-hand controls - Functional aspects and principles for design (ISO 13851:2019)".

The two-hand control device (ZHS) must be mounted in such a way that the danger point cannot be reached if one of the control devices is released. The gripping speed (K) is assumed to be 1600 mm/s.

According to the currently valid press standards, the safety distance (S) is calculated as follows  $S = (K \times T) + C$

S: Minimum distance (mm) from the danger area to the ZHS

K: 1600 mm/s

T: Response time of the entire system

C: an additional distance in millimetres

For ZHS with masking, C can be zero; without masking, C > 250 mm must correspond.

The position of the two-hand control must be selected so that it cannot be operated while a part of the body is in the danger zone!

**The following applies to portable two-hand controls:**

- The controls must be stable in normal use.
- They must be fitted with devices to prevent any change of position during operation. (e.g. stand with large mass, lockable castors, etc.)
- Arrangements shall be made for the maintenance and testing the required safety distance between the actuators and the danger area (location, e.g. by a spacer ring)
- If an emergency stop is planned, it must be indicated whether this device is active or inactive (DIN EN ISO 16092-1, 5.4.5.3)
- The two-hand control may only be operated from the operating side where it is plugged in (note cable length).

**Constructive aspects:**

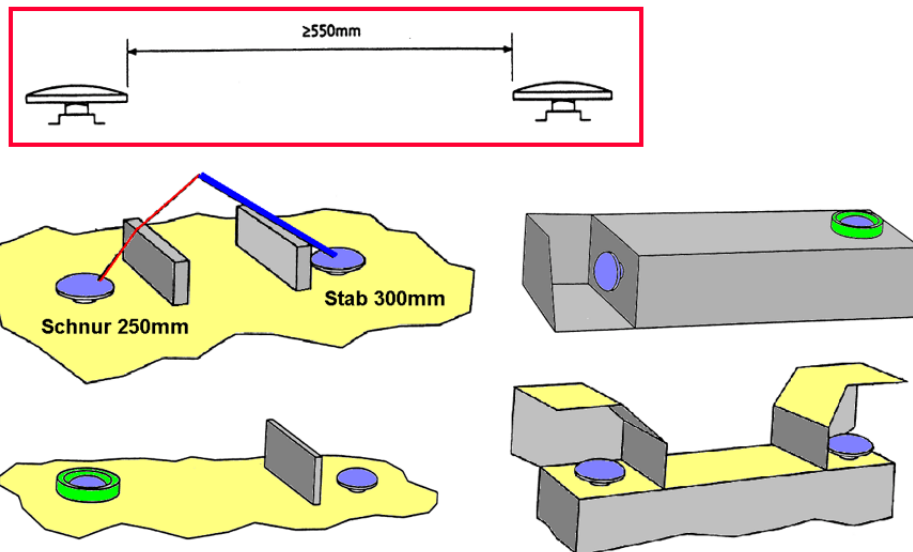

**Types of two-hand controls and the Minimum security requirements**

Requirements	Types				
	I	II	III		
			A	B	C
Use of both hands	x	x	x	x	x
Relationship between input- and output signals	x	x	x	x	x
Termination of the output signal	x	x	x	x	x
Avoid inadvertent operation and bypass	x	x	x	x	x
Generating the output signal again	x*)	x	x	x	x
Synchronous operation			x	x	x

\*) When selecting a Type I two-hand circuit, it is always necessary to determine whether the characteristics of synchronous actuation and re-generation of an output signal can be neglected, and it is particularly important that the risk assessment has been carried out with great care.

**Checklist two-hand control**

- Stopping time, safety distance specified?
- Required safety distance maintained?
- Is there a visual connection to the danger area?
- Two-hand control not easy to bypass (switching element arrangement according to DIN EN ISO 13851)?
- Connection cable and plug OK?
- Stroke interruption when a button is released?
- Reset check (depending on the defined type/level)?
- Does the two-hand control correspond to the required type according to DIN EN ISO 13851 (applicable product standard)?